

Summer Prealgebra review; show your work

1. Round 1.5292 to the nearest hundredth.

2. Round 9.569 to the nearest tenth.

3. Convert $2\frac{8}{9}$ into an improper fraction.

4. Convert $\frac{55}{7}$ into a mixed number.

5. Perform the operation and reduce the answer fully.
Make sure to express your answer as a simplified fraction.

$$-\frac{2}{5} \cdot -\frac{8}{5}$$

6. Perform the operation and reduce the answer fully.
Make sure to express your answer as a simplified fraction.

$$-\frac{1}{2} \div 8$$

7. Evaluate the expression shown below and write your answer as a fraction or mixed number in simplest form.

$$\frac{1}{12} + \frac{3}{16}$$

8. Evaluate the expression shown below and write your answer as a fraction or mixed number in simplest form.

$$\frac{1}{8} - \frac{7}{48}$$

9. Convert $\frac{1}{30}$ into a decimal.

Summer Prealgebra review; show your work

10. Convert $\frac{13}{50}$ into a decimal.

11. Convert $.9\overline{3}$ to a fraction in simplest form.

12. Convert $.6\overline{4}$ to a fraction in simplest form.

13. Point G is located at -10 . Points H and I are each 6 units away from Point G. Where are H and I located?

14. Point N is located at -6 . Point O is 3 greater than Point N. Where is O located?

15. Compute:

$$3 - 8$$

16. Compute:

$$-2 - (-10)$$

17. Look at the expression below. Do not solve. State if the answer would be positive, negative, or zero, and explain why.

$$-13 \times -15$$

The answer would be _____ because this is a

_____ problem and

_____.

This word bank also applies to question 18.

Word bank 1: (a) positive, (b) zero, (c) negative

Word bank 2: (a) subtraction, (b) division, (c) addition, (d) multiplication

Word bank 3: (a) one number is positive and one number is negative, (b) zero divided by anything is zero, (c) anything times zero is zero, (d) both numbers are negative, (e) both numbers are positive

Summer Prealgebra review; show your work

18. Look at the expression below. Do not solve. State if the answer would be positive, negative, or zero, and explain why.

$$20 \div -6$$

The answer would be _____ because this is a

word bank 1

_____ problem and

word bank 2

_____.

word bank 3

19. Evaluate.

$$|13 - 19|$$

20. Evaluate.

$$-8 - |11|$$

21. Simplify the expression below using order of operations.

$$\frac{-9 - 3}{7 - 6} + \frac{1 + 8}{(-1)^3 - (-2)}$$

22. Simplify the expression below using order of operations.

$$\left[\left((-3)^2 \times 7^1 \right) - (-4 + 3) \right] \div 1$$

23. Identify the constant term in the expression below.

$$10c + 5$$

Summer Prealgebra review; show your work

24. Identify the coefficient in the expression below.

$$p + 2$$

25. What is the value of the expression $6z - 6$ when $z = 2$?

26. What is the value of the expression $7x + 5y$ when $x = 4$ and $y = 10$?

27. Which expression is equivalent to $v + 3 - 9v$?

- A. $v - 6$ B. $3 - 8v$
C. $-11v$ D. $-5v$

28. Which expression is equivalent to $5h + h + 9h$?

- A. $1 + 14h$ B. $h + 14$
C. $15h$ D. $5h$

29. Find an expression which represents the sum of $(x - 5y)$ and $(-6x + y)$ in simplest terms.

30. Find an expression which represents the sum of $(-10x - 2)$ and $(-6x + 1)$ in simplest terms.

31. Use the distributive property to write an equivalent expression.

$$2(6q + 4)$$

Summer Prealgebra review; show your work

32. Rewrite in simplest terms:

$$-9(4n - 3) - 3(-n - 8)$$

33. Identify the greatest common factor of $15b$ and $15bz$.

34. Which expression is equivalent to the expression below?

$$7(6s) + 6s$$

- A. $84s$ B. $12s + 7$
C. $48s$ D. $42s + 6s^2$

35. Simplify to a single power of 2:

$$2^2 \times 2^5$$

36. Use an exponent to condense the expression below. Then compute.

$$4 \times 4$$

37. Evaluate.

$$(-7)^1$$

38. Write the number 1.6×10^{-6} in standard form.

39. Write the number 3.9×10^4 in standard form.

40. Write the number 0.0000054 in scientific notation.

41. What is the image point of $(-8, 9)$ after a translation right 3 units and down 1 unit?

Summer Prealgebra review; show your work

42. What is the image point of $(1, 4)$ after a translation left 5 units and down 5 units?

43. Translate the figure 1 unit left and 4 units up.

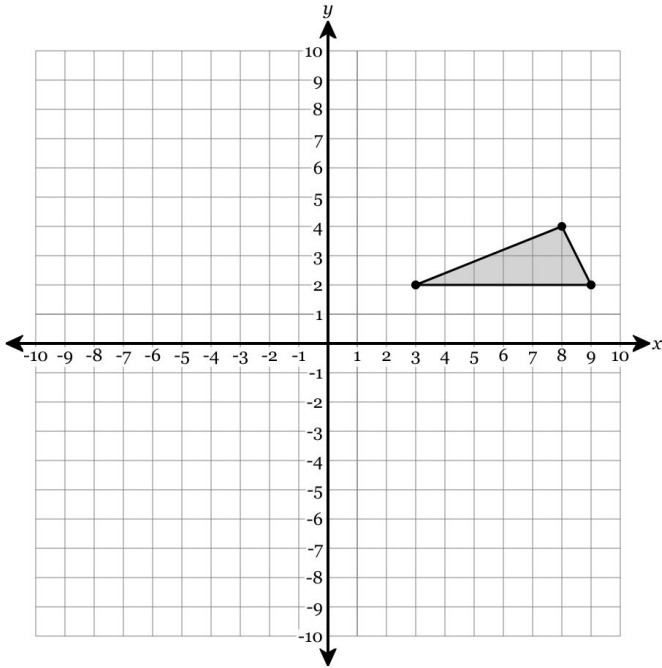

44. Solve for x.

$$-\frac{7}{4} = \frac{x}{8}$$

45. Solve for x.

$$\frac{x}{14} = \frac{5}{7}$$

46. Solve for x.

$$\frac{2}{7} = \frac{x}{42}$$

47. Solve for x.

$$\frac{21}{x} = -\frac{7}{3}$$

48. Solve for x.

$$\frac{14}{x} = -\frac{2}{3}$$

Summer Prealgebra review; show your work

49. Measure $\angle UVW$ with a protractor and write your answer to the nearest degree.

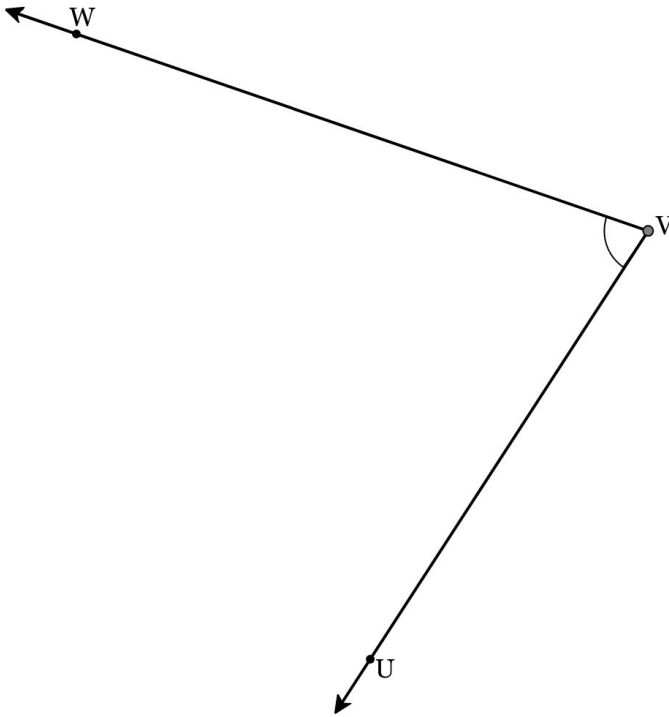

50. Given \overline{NOP} , use a protractor to measure $\angle NOQ$ and $\angle POQ$. Also determine the *sum* of two angle measurements.

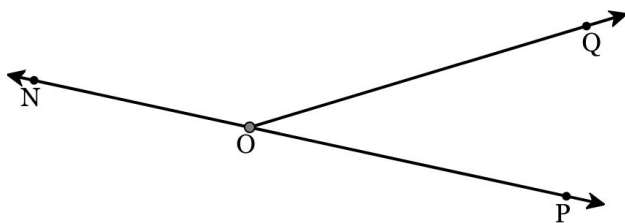

$m\angle NOQ = \underline{\hspace{2cm}}^\circ$ $m\angle POQ = \underline{\hspace{2cm}}^\circ$
 $m\angle NOQ + m\angle POQ = \underline{\hspace{2cm}}^\circ$

51. Find the measure of the missing angles.

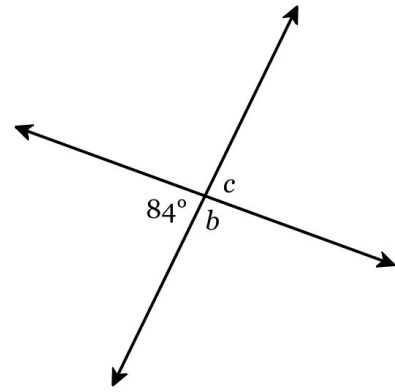

$b = \underline{\hspace{2cm}}^\circ$ $c = \underline{\hspace{2cm}}^\circ$

52. Given $m \parallel n$, find the value of x .

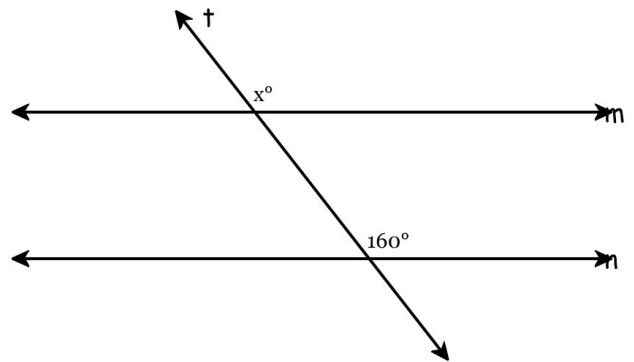

53. What value of x is the solution to the equation below?

$$-12 + x = -7$$

54. Solve for b .

$$-32 + 10b = -22$$

Summer Prealgebra review; show your work

55. Solve for x :

$$-9x + 5 = -4x - 5$$

56. Solve. $2(4y + 6) = -36$

57. Select the values that make the inequality $c \leq -2$ true. (Numbers written in order from least to greatest going across.)

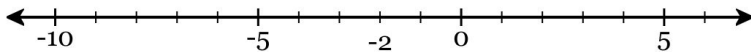

- | | | |
|---------------------------------|-------------------------------|---------------------------------|
| <input type="checkbox"/> -10 | <input type="checkbox"/> -7 | <input type="checkbox"/> -5 |
| <input type="checkbox"/> -3 | <input type="checkbox"/> -2.1 | <input type="checkbox"/> -2.01 |
| <input type="checkbox"/> -2.001 | <input type="checkbox"/> -2 | <input type="checkbox"/> -1.999 |
| <input type="checkbox"/> -1.99 | <input type="checkbox"/> -1.9 | <input type="checkbox"/> -1 |
| <input type="checkbox"/> 1 | <input type="checkbox"/> 3 | <input type="checkbox"/> 6 |

58. Solve the inequality and graph the solution on the line provided.

$$2x - 15 < -9$$

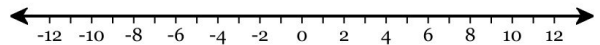

59. State the coordinates of the point.

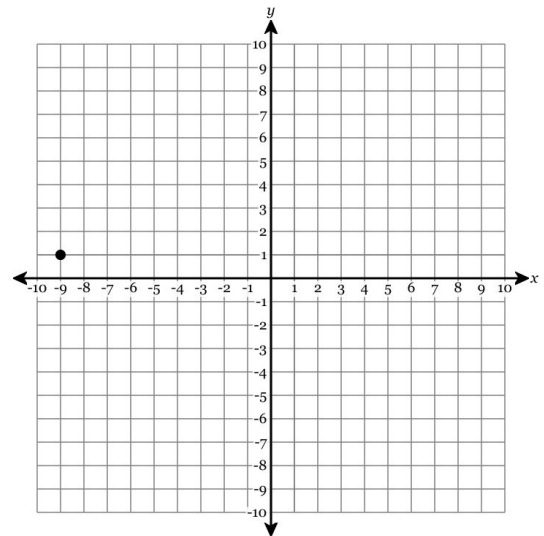

Summer Prealgebra review; show your work

60. Write an equation for z in terms of c that corresponds to the table below.

| c | z |
|-----|-----|
| 5 | 30 |
| 6 | 36 |
| 7 | 42 |
| 8 | 48 |
| 9 | 54 |

61. Find the value of $f(3)$.

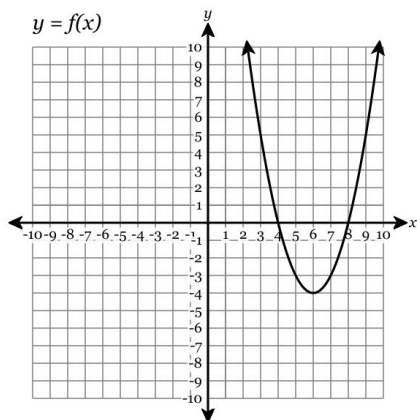

62. Given the function below, fill in the table of values and use the table values to graph.

$$y = -5$$

| x | $y = -5$ |
|-----|----------|
| -3 | |
| -2 | |
| -1 | |
| 0 | |
| 1 | |
| 2 | |
| 3 | |

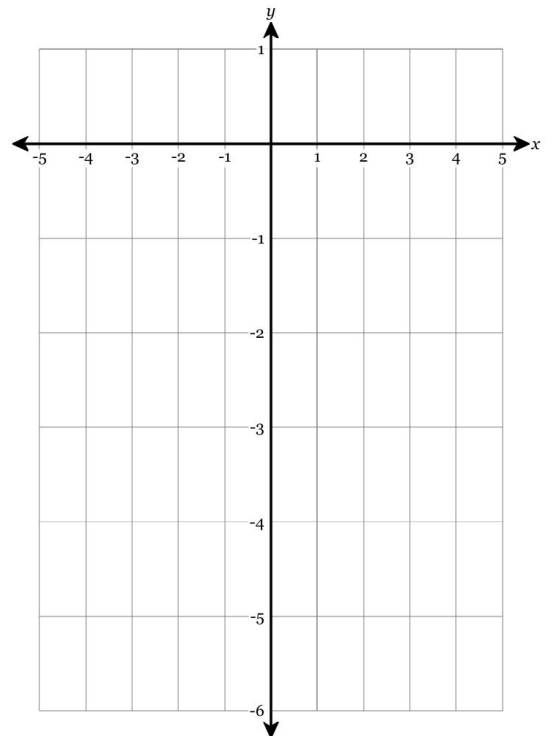

Summer Prealgebra review; show your work

63. Graph the line $x = -7$ on the axes shown below.

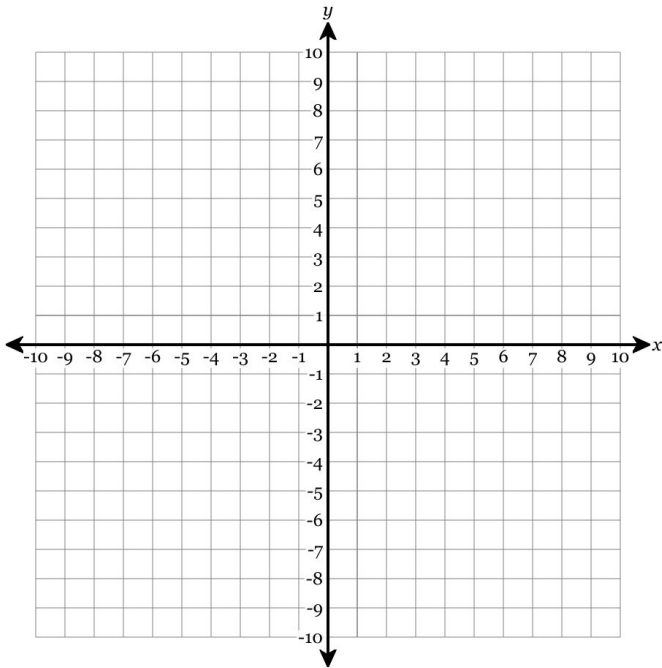

64. Find the volume in cubic meters of the right rectangular prism shown below.

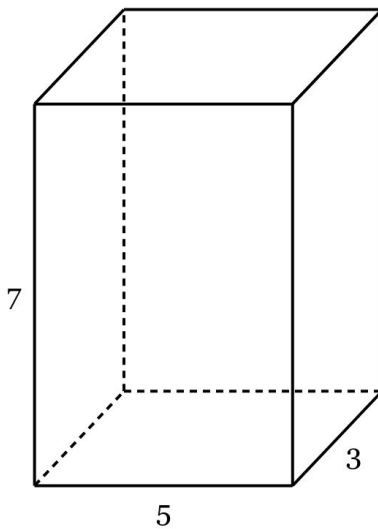

65. A cylinder has a base radius of 10 inches and a height of 4 inches. What is its volume in cubic inches, to the nearest tenths place?

66. Find the volume of a right circular cone that has a height of 9.9 in and a base with a diameter of 10.1 in. Round your answer to the nearest tenth of a cubic inch.

67. Express in simplest radical form: $\sqrt{48}$

68. Find the length of the third side. If necessary, round to the nearest tenth.

